

DIMENSIONS

VBF FLAT TOP CABINET

Redefine your comfort zone™ | www.titus-hvac.com

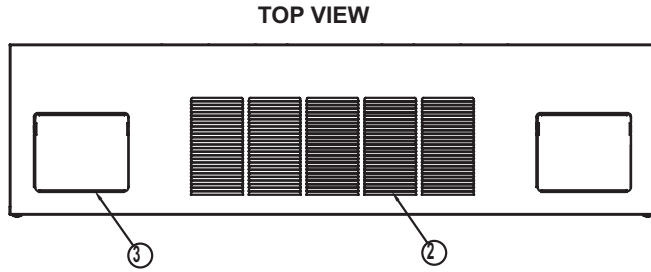

1. Control Box
2. Stamped Supply Air Grille
3. Control Access Door
4. Coil
5. Coil Connections (2-Pipe Shown)
6. Motor/Blower(s) Assembly
7. Condensate Connection.
8. Filter
9. Fresh Air Damper Opening (optional) = 2" x "C"
10. Electric Heaters (optional)

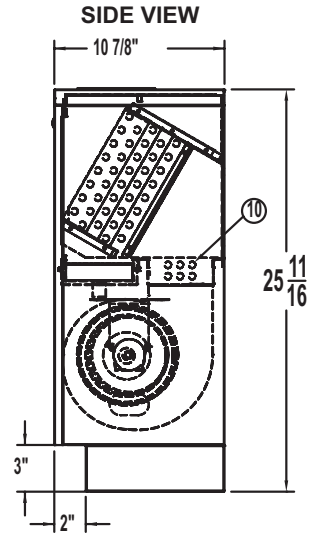
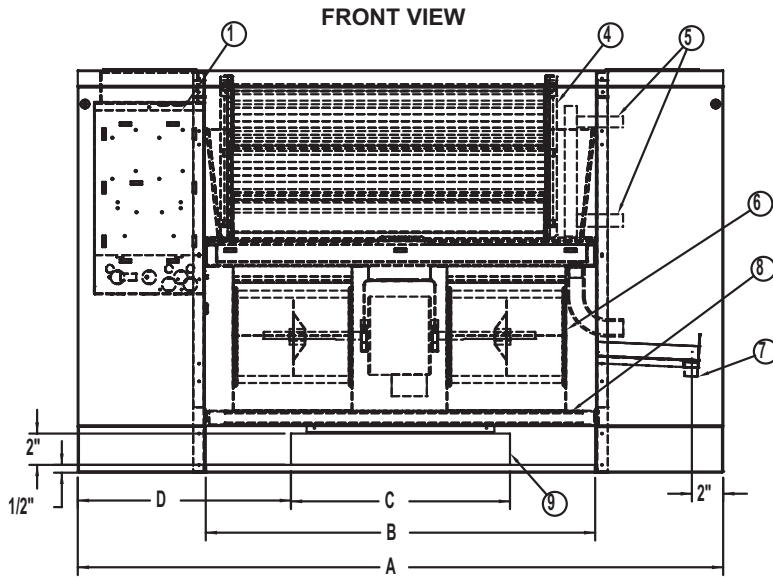

Note: Right Hand Unit Shown

Model	Dimensions (inches)					Approx. Weight (pounds)
	A	B	C	D	Filter	
VBF02	34¼	18	12	11	17 x 10 x 1	95
VBF03	37¼	21	12	12	20 x 10 x 1	104
VBF04	41¼	25	12	14	24 x 10 x 1	106
VBF06	52¼	36	24	14	35 x 10 x 1	128
VBF08	60¼	44	24	18	43 x 10 x 1	146
VBF10	70¼	54	36	17	(2)26 x 10 x 1	178
VBF12	80¼	64	36	22	(2)31 x 10 x 1	186

All dimensions are in inches